

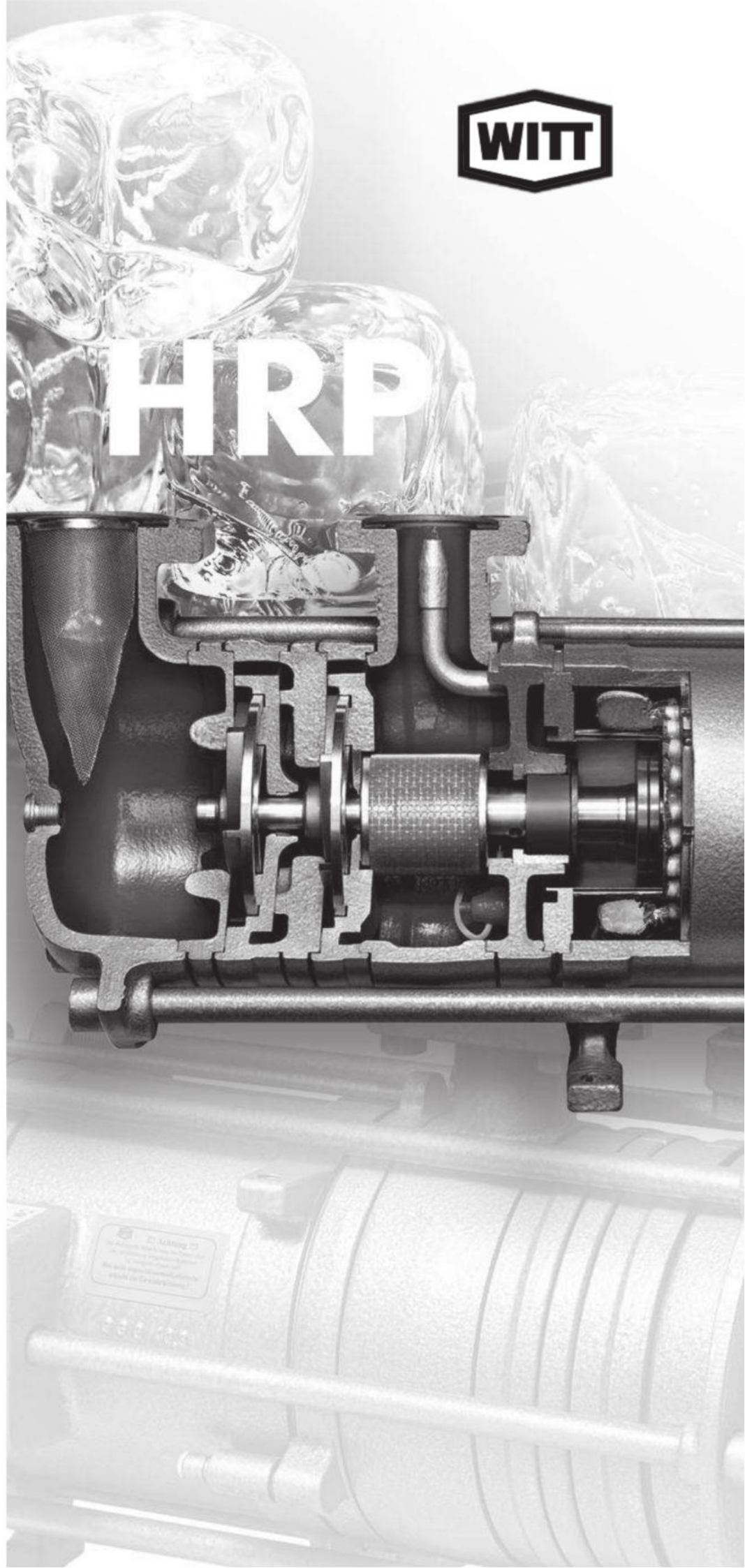

**Hermetic
refrigerant pumps**
*Installation and
operating instructions*

HRP 3232
HRP 5040
HRP 5050
HRP 8050
HRP 10080

HRP



4. TECHNICAL DATA

4.1 GENERAL INFORMATION

DESCRIPTION	Unit	HRP 3232	HRP 5040	HRP 5050	HRP 8050	HRP 10080
Volume refrigerant side	ltr.	1,1	2,8	5	5,5	6,35
Volume transformer oil	ltr.	0,75	1	1,5	1,5	1,6
Weight pump with counterflanges	kg	43	55	83	83 / 110**	117
Sound pressure level	dB(A)	< 70	< 70	< 70	< 70	< 70
Class of terminal box insulation	IP	54	54	54	54	54
Box cable sockets prepared to	PG	1 x M16; 1 x M20	1 x M16 1 x M20	1 x M16 1 x M20;	1 x M16 1xM20/M25 **	1 x M16 1 x M25

** Model HRP8050-2, Model HRP 5050-90 and 8050-90

4.2 ELECTRICAL DATA

(applies to all pressure stages)

50 Hz 3 x 400 V								
DESCRIPTION	Unit		HRP 3232	HRP 5040	HRP 5050	HRP 8050	HRP 10080	
Speed	n	[min ⁻¹]	2900	2900	2900	2900	2900	
max. power consumption								
with NH ₃	I _{max}	[A]	1,5	4,7	5,5	7,0	13,0	
with CO ₂	I _{max}	[A]	2,1	-	7,0	10,0	16,0	
With HFC, HFO, e.g. R134a	I _{max}	[A]	2,2	5,2	8,5	16,0**	20,0	
Motor power factor								
with NH ₃	Cos φ	[-]	0,61	0,63	0,68	0,80	0,79	
with CO ₂	Cos φ	[-]	0,83	-	0,80	0,88	0,85	
With HFC, HFO, e.g. R134a	Cos φ	[-]	0,84	0,63	0,85	0,85**	0,89	
Effective motor power	N	[kW]	$N_{\text{wirk}} = \sqrt{3} \times (U \times I_{\text{wirk}} \times \cos \varphi)$ (values at operating point – see selection tool)					

60 Hz 3 x 460 V								
DESCRIPTION	Unit		HRP 3232	HRP 5040	HRP 5050	HRP 8050	HRP 10080	
Speed	n	[min ⁻¹]	3500	3500	3500	3500	3500	
max. power consumption								
with NH ₃	I _{max}	[A]	2,0	6,2	7,3	10,0	16,0	
with CO ₂	I _{max}	[A]	2,6	-	9,5	16,0	24,0	
With HFC, HFO, e.g. R134a	I _{max}	[A]	2,9	6,9	11,5	23,5**	28,0	
Motor power factor								
with NH ₃	Cos φ	[-]	0,88	0,86	0,87	0,90	0,90	
with CO ₂	Cos φ	[-]	0,92	-	0,90	0,90	0,93	
With HFC, HFO, e.g. R134a	Cos φ	[-]	0,93	0,86	0,91	0,85**	0,93	
Effective motor power	N	[kW]	$N_{\text{wirk}} = \sqrt{3} \times (U \times I_{\text{wirk}} \times \cos \varphi)$					(values at operating point – see selection tool)

* Measure the maximum current during commissioning and set the overload protection to this value, do not exceed I_{max} for the relevant refrigerant.

** The HRP8050-2 model requires a special motor for Freons and HFO, e.g. R134a with the dimensions and data of the motor for an HRP10080.

	HRP			
	5040	5050	8050	10080
L	540	520	555	725
B	260	310	310	355
H	283	349	351	362
a1	150	180	180	180
a2	228	234	255	302
a3	196	170	170	290
b1	105	133	133	133
b2	154	174	174	222
c	53	53	66	70
d1	60,3	60,3	88,9	114,3
d2	48,3	60,3	60,3	88,9
l1	155	155	178	212
m1	115	145	145	145
m2	168	204	206	217
m3	130	190	190	190

	HRP			
	5040	5050	8050	10080
f1	343	343	470	466
f2	346	343	343	---
f3	376	373	373	472
h1	138	138	179	179
h2	141	138	138	179

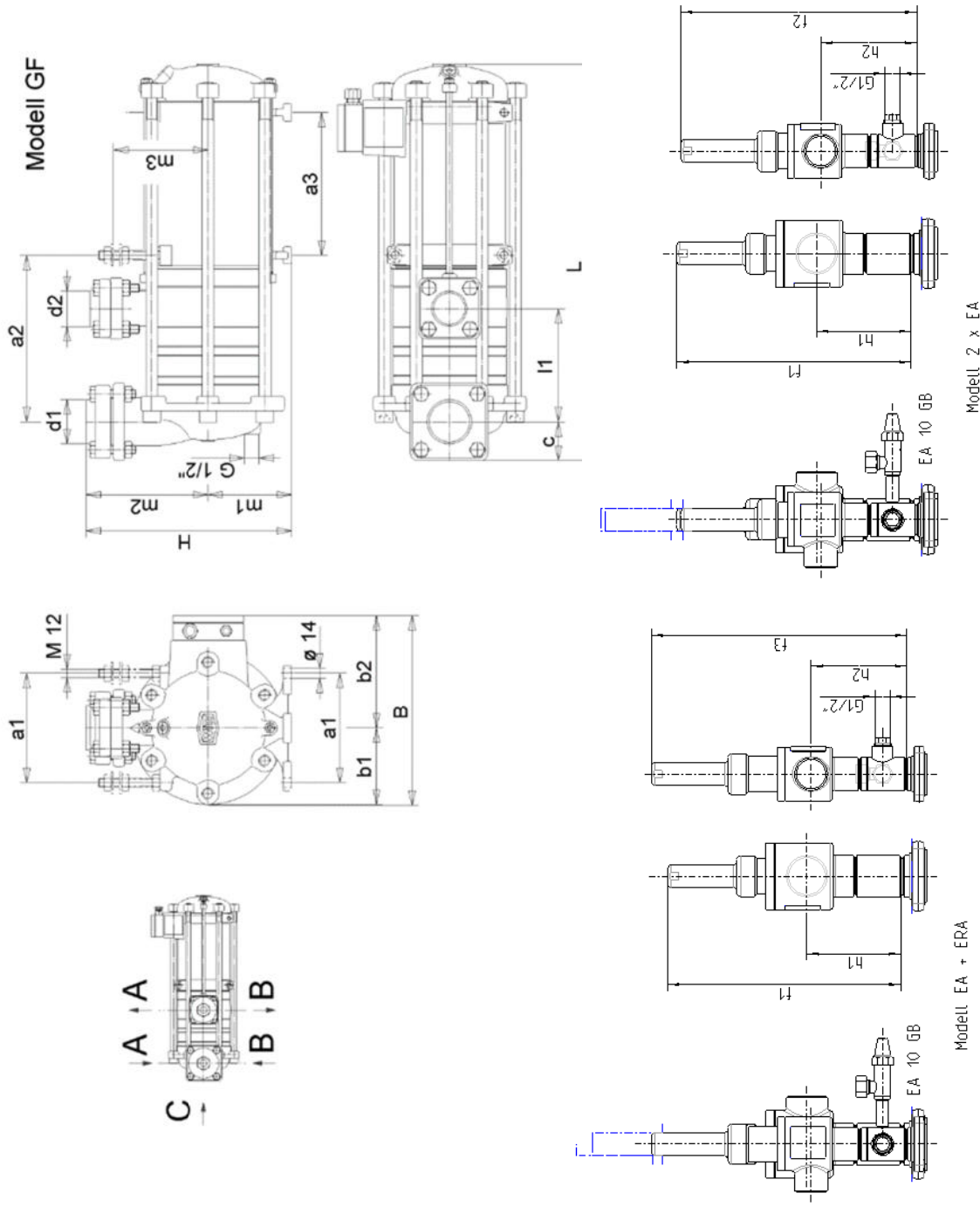

Fig. 2a HRP 5040/5050/8050/10080

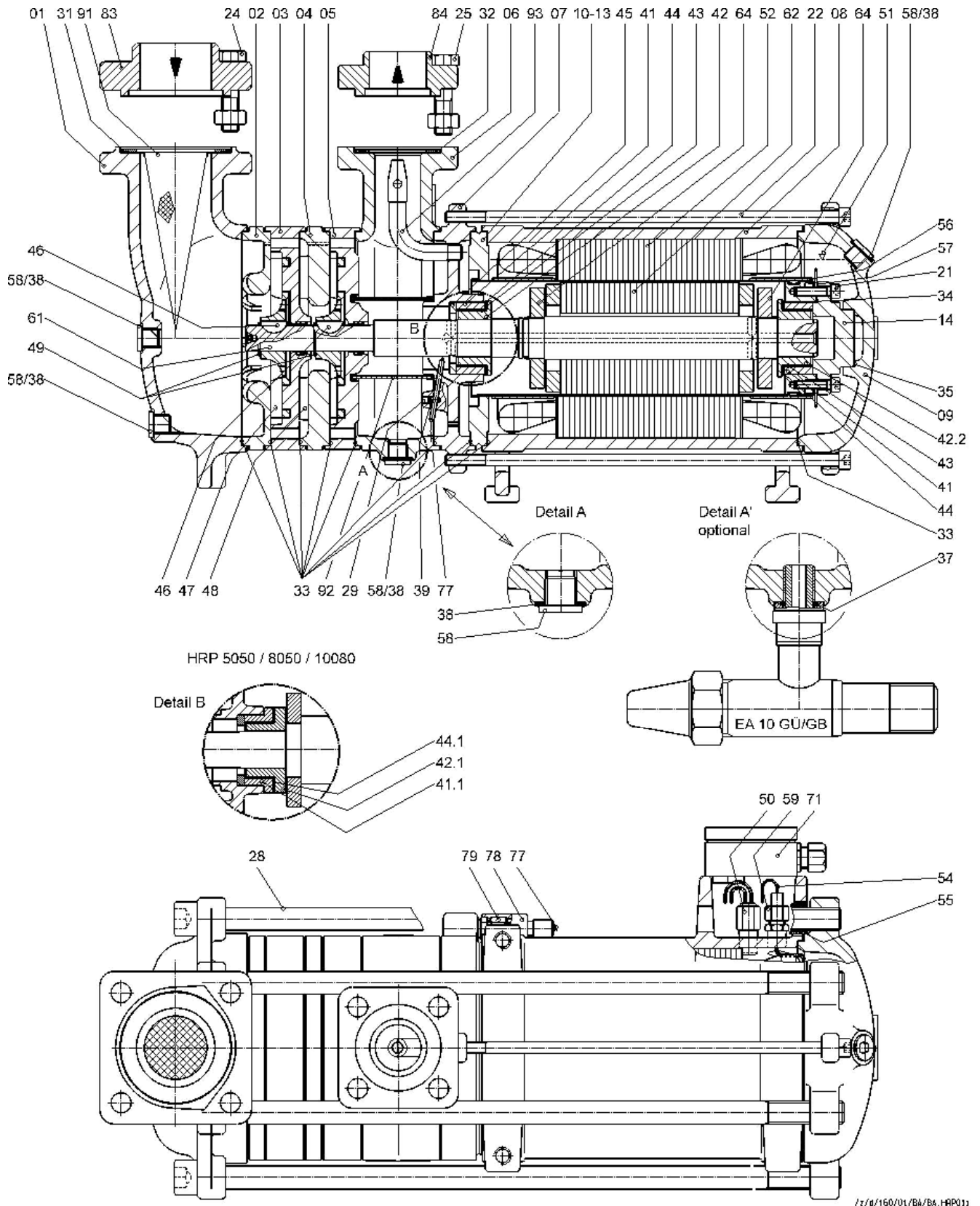

Fig. 3b HRP5040/HRP 5050/HRP 8050/HRP 10080

4.7 DESCRIPTION OF OPERATION

From the surge drum refrigerant liquid flows into the suction chamber of the pump. In the suction connection a conical screen is placed. A special design of the suction chamber reduces the inlet friction. The pressure is increased in two stages through impellers and intermediate pieces. A built in ejector is designed to provide adequate cooling of bearings and motor.

By the differential pressure in the pump some of the liquid refrigerant is bled to the back bearings through the hollow shaft. On top of each intermediate piece there is a small bypass hole connecting the suction and discharge side. When gas has collected in the discharge chamber it can vent through these holes to the suction chamber and from there returning to the surge drum. It is important that the downleg must be designed in such a way that the pump venting can take place (see chapter 6).

For the HRP 3232, 5050-90 and 8050-90 the design of a vertical motor shaft allows the free flow of any gas bubbles that may form.

Pumps with horizontal motor shaft (HRP 5040, HRP 5050, HRP 8050 and HRP 10080) are equipped with a sensor behind the bearing filter to detect wear of the bearings. While the pump is at stand still at connection (position 77) on the out-side of the pump you can measure the electrical resistance through the shaft. If there is a short circuit, i.e. down to earth, the bearings are worn and the pump should be sent in for repair.

Transformer oil is used in the stator housing between the motor can and the outside casing. This oil is useful to prevent moisture entering the stator, conducts the motor heat away to the outside casing.

A thermistor is integrated in the stator windings to sense any abnormal rise in temperature and interrupt the motor supply.

4.8 PERFORMANCE CHARACTERISTIC TABLE

50 Hz, 3 x 400V													
	Druckdifferenz Δp [bar]								Volumenstrom V[m ³ /h]				
	Pressure difference Δp [bar]								Volume flow V[m ³ /h]				
	R717		R22, R134a		R507		CO ₂		HRP 3232	HRP 5040	HRP 5050	HRP 8050	HRP 10080
Delivery head	at evaporation temperature t_0												
H [m]	0°C	-40°C	0°C	-40°C	0°C	-40°C	0°C	-40°C					
2	0,13	0,14	0,25	0,28	0,23	0,25	0,18	0,22	5,6	13,2	15	30,0	55,0
4	0,25	0,27	0,50	0,55	0,45	0,51	0,36	0,44	5,0	13,0	14,6	29,9	53,7
6	0,38	0,41	0,75	0,83	0,68	0,76	0,55	0,66	4,7	12,6	14,4	29,4	53,0
8	0,50	0,54	1,00	1,10	0,91	1,02	0,73	0,88	4,4	12,0	14,2	28,7	52,5
10	0,63	0,68	1,26	1,38	1,14	1,27	0,91	1,09	4,2	10,5	13,9	28,0	52,1
15	0,94	1,02	1,88	2,07	1,70	1,91	1,37	1,64	3,6	9,0	13,2	26,1	50,3
20	1,25	1,35	2,51	2,76	2,27	2,54	1,82	2,19	3,0	8,0	12,3	24,2	46,8
25	1,57	1,69	3,14	3,45	2,84	3,18	2,28	2,74	2,3	5,2	11,5	22,4	42,6
30	1,88	2,03	3,77	4,14	3,41	3,82	2,73	3,28	-	1,5	10,4	20,1	37,9
35	2,19	2,37	4,40	4,83	3,97	4,45	3,19	3,83	-	-	9,1	18,2	32,7
40	2,51	2,71	5,02	5,52	4,54	5,09	3,64	4,38	-	-	7,5	15,0	26,6
45	2,82	3,05	5,65	6,21	5,11	5,72	4,10	4,93	-	-	5,2	12,5	20,4
50	3,13	3,39	6,28	6,90	5,68	6,36	4,55	5,47	-	-	2,0	9,1	10,9
55	3,45	3,72	6,91	7,59	6,24	7,00	5,01	6,02	-	-	-	-	-
60	3,76	4,06	7,53	8,28	6,81	7,63	5,46	6,57	-	-	-	-	-
65	4,07	4,40	8,16	8,97	7,38	8,27	5,92	7,11	-	-	-	-	-
70	4,39	4,74	8,79	9,66	7,95	8,90	6,37	7,66	-	-	-	-	-
75	4,70	5,08	9,42	10,35	8,52	9,54	6,83	8,21	-	-	-	-	-

60 Hz, 3 x 460V													
	Druckdifferenz Δp [bar]								Volumenstrom V [m ³ /h]				
	Pressure difference Δp [bar]								Volume flow V [m ³ /h]				
Delivery head	R717		R22, R134a		R507		CO ₂		HRP 3232	HRP 5040	HRP 5050	HRP 8050	HRP 10080
	at evaporation temperature t_0												
H [m]	0°C	-40°C	0°C	-40°C	0°C	-40°C	0°C	-40°C					
2	0,13	0,14	0,25	0,28	0,23	0,25	0,18	0,22	5,2	13,9	16,4	35	66,1
4	0,25	0,27	0,50	0,55	0,45	0,51	0,36	0,44	5,2	13,8	16,3	35	66,0
6	0,38	0,41	0,75	0,83	0,68	0,76	0,55	0,66	5,1	13,6	16,2	35	65,6
8	0,50	0,54	1,00	1,10	0,91	1,02	0,73	0,88	5,0	13,4	16,0	35	64,8
10	0,63	0,68	1,26	1,38	1,14	1,27	0,91	1,09	4,8	13,3	15,9	35	63,7
15	0,94	1,02	1,88	2,07	1,70	1,91	1,37	1,64	4,7	12,8	15,4	34,8	60,8
20	1,25	1,35	2,51	2,76	2,27	2,54	1,82	2,19	4,4	12,1	14,9	32,8	57,9
25	1,57	1,69	3,14	3,45	2,84	3,18	2,28	2,74	4,1	11,2	14,3	30,7	54,8
30	1,88	2,03	3,77	4,14	3,41	3,82	2,73	3,28	3,6	10,1	13,7	28,5	51,3
35	2,19	2,37	4,40	4,83	3,97	4,45	3,19	3,83	3,0	8,8	13,1	26,6	47,7
40	2,51	2,71	5,02	5,52	4,54	5,09	3,64	4,38	2,2	7,3	12,3	24,7	44,0
45	2,82	3,05	5,65	6,21	5,11	5,72	4,10	4,93	1,1	5,7	11,5	22,9	39,7
50	3,13	3,39	6,28	6,90	5,68	6,36	4,55	5,47	-	3,6	10,5	20,7	34,1
55	3,45	3,72	6,91	7,59	6,24	7,00	5,01	6,02	-	-	9,4	18,3	28,5
60	3,76	4,06	7,53	8,28	6,81	7,63	5,46	6,57	-	-	7,9	15,7	23,0
65	4,07	4,40	8,16	8,97	7,38	8,27	5,92	7,11	-	-	6,0	13,0	14,0
70	4,39	4,74	8,79	9,66	7,95	8,90	6,37	7,66	-	-	2,6	9,7	-
75	4,70	5,08	9,42	10,35	8,52	9,54	6,83	8,21	-	-	-	-	-

Table 1

In CO₂-systems with minimum flow line the given volume flow is not fully available for the system. A part of the pump volume flow will be by-passed via minimum flow line back into the vessel.

Required diameter of the downleg to the pumps					
	HRP 3232	HRP 5040	HRP 5050	HRP 8050	HRP 10080
50 Hz	DN 80	DN 100	DN 125	DN 150	DN 250
60 Hz	3"	4" / 5"	5"	6" / 8"	10"

Table 3



Under no circumstances shall the maximum velocity of ammonia systems in the downleg exceed **0,3 m/s!**

Systems operating at 60Hz have to select a DN125 (5") suction line when the delivery head is below 25 m for HRP5040, whereas the HRP8050 requires below 40 m a DN200 (8") suction line diameter.

The conical suction filter that comes with the pump must be fitted at all times to protect the pump from any contamination!

6.4 PUMP DISCHARGE LINE

The design of the discharge line is less critical to the system operation. A liquid velocity of 1.5 m/s is normally recommended.



A non-return valve (this is usually a combined stop/check valve type ERA) in the discharge line is required when a backwards flow from the discharge to the suction side is possible. This may be the case, when:

- several pumps are connected to one discharge manifold
- the static head to the coolers is high.

A non-return valve should be mounted as close as possible to the discharge flange. If a larger distance is required, an additional vent line should be installed to prevent a possible gas blockage.

VENT LINE

If the suction line needs to be closed during stand-still or the check valve is installed in a distance from the pump an additional vent line is required.

A minimum flow line is always recommended in CO₂ systems, which also vents the pump during stand-still.

To avoid backflow of refrigerant during stand-still it is important that each pump is individually connected with a separate vent line immediately in front of the check valve on the delivery side to the top of the surge drum.

The stop valve after the orifice shall be DN20 (3/4") respective DN25 (1") if installed in the part of the vent line that can contain liquid.

If the valve is installed in the gas part of the vent line, immediately in front of the connection point to the CO₂ vessel a smaller valve is sufficient, e.g. DN10 (0.4"). The stop valve must be locked in an open position and marked "do not close during normal operation".



In application with a non-return valve or solenoid valve liquid may be trapped. When this liquid is warmed up, the pressure increases rapidly to an unacceptable value and the piping may fracture.

Adequate precautions must be taken by the installer to prevent any liquid from becoming trapped.

PIPING FROM THE CONDENSER IN CO₂ SYSTEMS

From experience it has proven good practice to enter with the line from the condenser into the surge drum below the liquid level and as such minimize the surface available for condensation in the vessel.

6.5 PROTECTION OF THE PUMP

6.5.1 REQUIRED MINIMUM FLOW

To provide the pumps with sufficient liquid refrigerant for lubrication and cooling it is important to maintain a minimum flow per following table through the pump at all times. This can be achieved when the design or the control system ensures there is always sufficient flow to the evaporators.

When the control system allows that a major part or all evaporators can be closed, a by-pass line is required to protect the pump against too high pressure (see chap. 6.5.2) and ensure a minimum flow.

Required minimum flow				
	V @ 50 Hz		V @60 Hz	
	m ³ /h	gal/min	m ³ /h	gal/min
HRP3232	0,6	2.6	0,7	3.1
HRP5040	1,2	5.3	1,5	6.6
HRP5050	3,0	13,2	3,5	15,4
HRP8050	5,0	22	5,5	24
HRP10080	8,0	35	9,6	42



TH.WITT
Kältemaschinenfabrik
GmbH

Lukasstraße 32, 52070 Aachen, Germany
Tel. +49 241 18208-0
sales@th-witt.com

www.th-witt.com